

LS MECAPION DD MOTOR SERIES

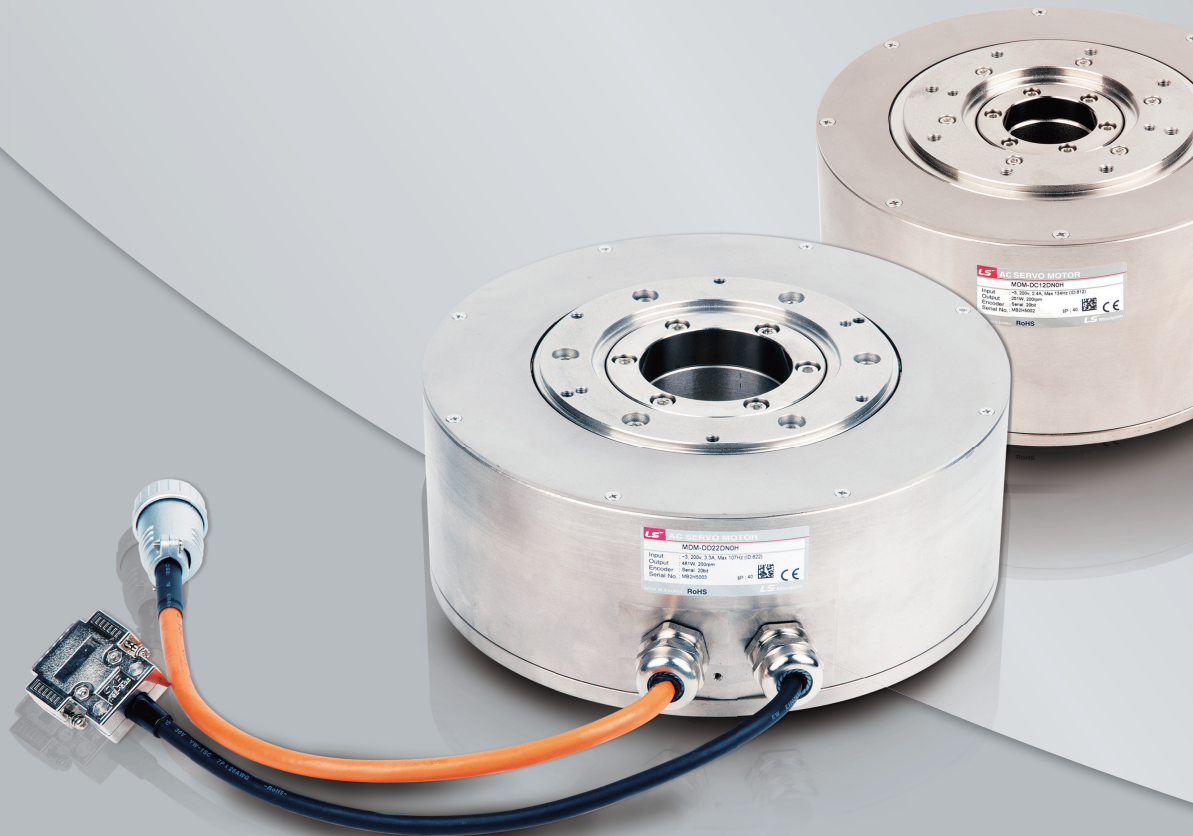

Direct drive motor reduces the number of mechanical components, and provide an intense mechanical system for highly dynamic applications. It allows manufactures to develop efficient and cost-effective production method.





Contents

- 04** Characteristics of Direct–Drive Rotary Motor
- 06** Designations
- 09** Specifications of Servo Drive
- 11** External dimension of Servo Drive
- 13** External dimension of Servo Motor
- 16** Specifications of Direct–Drive Rotary motor
- 18** Options and Peripherals

Characteristics

■ Characteristics of Direct-Drive Rotary Motor

□ Optimized low speed, high torque and high precision operation.

□ Reduced cogging torque and optimized torque design

- Select optimized permanent magnet, coil and slot ratio with analysis of Electromagnet
- Reduce torque ripple and maximize torque by applying sufficient No. of permanent magnet
- Adopt high power Neodymium(Nd-Fe-B) permanent magnet

□ High resolution of Optical Rotary Encoder with Biss protocol

- Providing 1,048,576 CPR of resolution(Single turn Absolute)
- Reduce cost and delivery time by using our own encoder technology

□ Compatibility with L7 Series AC Servo Drive(3phase AC 220V)

- Compatible with both standard I/O Type and Network(EtherCAT) Type

□ gearless

- No backlash
- High precision operation and shorten installing time
- Smooth rotation
- Reduced noise

□ Various line up

- Power(63W ~ 2,5KW), Rated Torque(3.0Nm ~ 160Nm), Rated Speed(150RPM ~ 200RPM)
- Frame size(Diameter) : 135mm, 175mm, 230mm, 290mm, 360mm(13 models)

Characteristics

■ Ratings and Specifications

- Insulation class : class B
- Protection level : IP 40
- Protection method : Fully enclosed self-cooling
- Vibration grade : V15
- Insulation resistance : 500VDC, over 10[10MΩ]
- AC withstanding voltage : 1800 VAC, 1 secon
- Input power supply : 200VAC



INDUSTRIAL DD MOTOR SYSTEM

Direct-Drive motor & Servo Drive Designations

Direct-Drive Designation

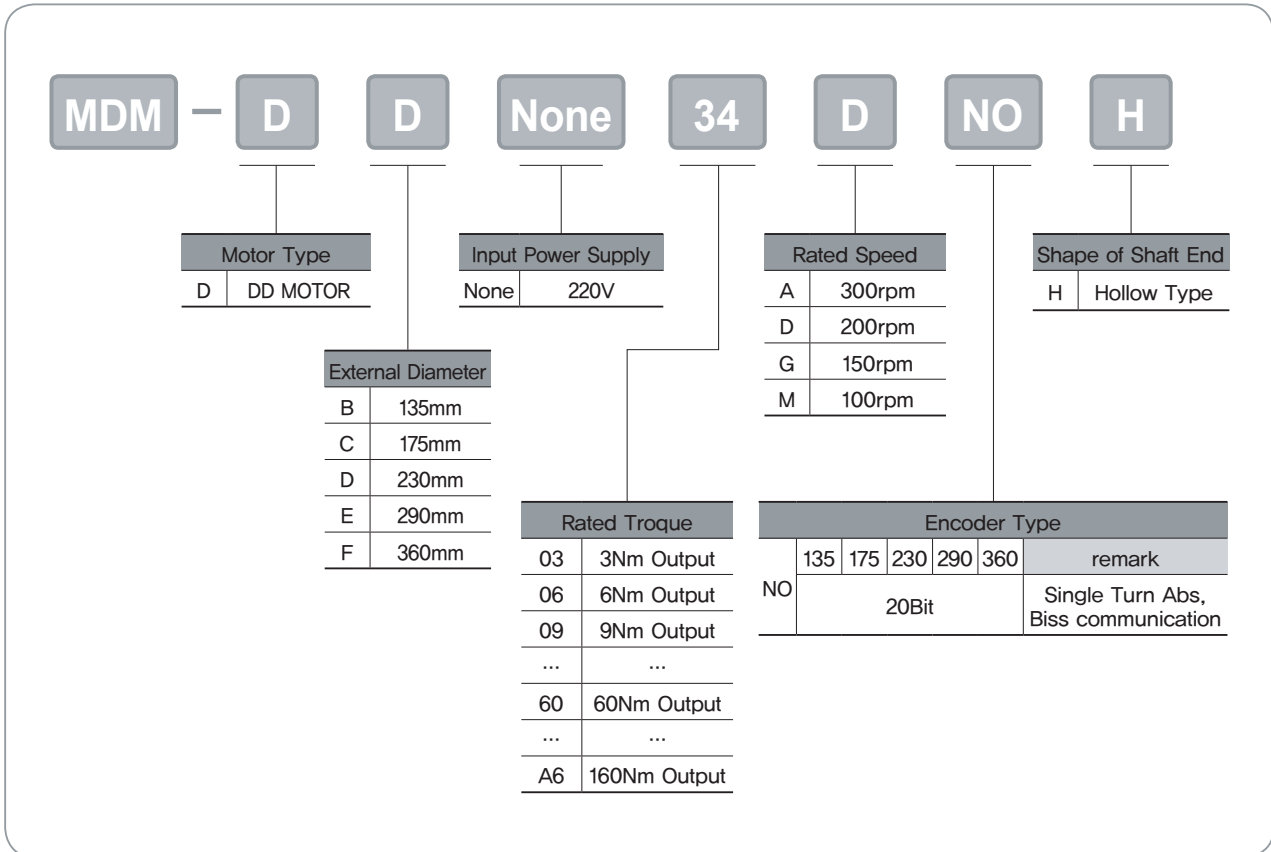

Servo Drive Designation

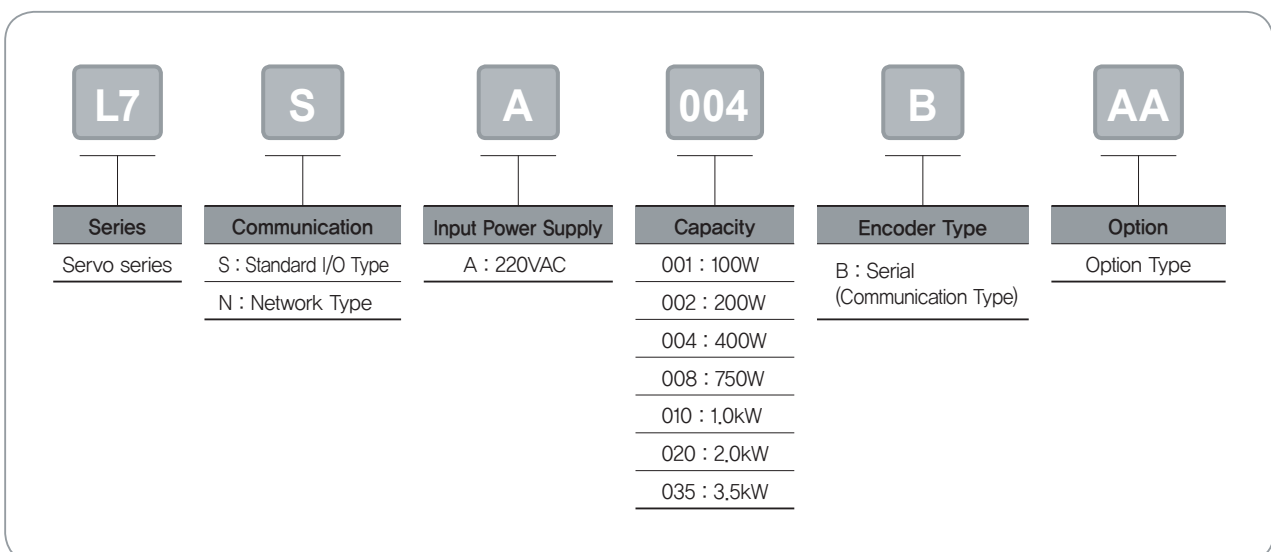

Motor designation

Applicable drive to motor

Rated Speed (RPM)	Maximum Speed (RPM)	External Diameter of Motor(Φ)	Applicable Motor	Applicable Drive	encoder type
200	500	Φ 135	DB03D	L7□A001B	20 bit single turn serial encoder (Biss/Absolute)
		Φ 135	DB06D	L7□A002B	
		Φ 135	DB09D	L7□A004B	
	500	Φ 175	DC06D	L7□A002B	
		Φ 175	DC12D	L7□A004B	
	400	Φ 175	DC18D	L7□A004B	
	500	Φ 230	DD12D	L7□A004B	
	400	Φ 230	DD22D	L7□A008B	
	400	Φ 230	DD34D	L7□A010B	
	300	Φ 290	DE40D	L7□A010B	
300	Φ 290	DE60D	L7□A020B		
150	250	Φ 360	DFA1G	L7□A020B	
		Φ 360	DFA6G	L7□A035B	

Appearances of Motor

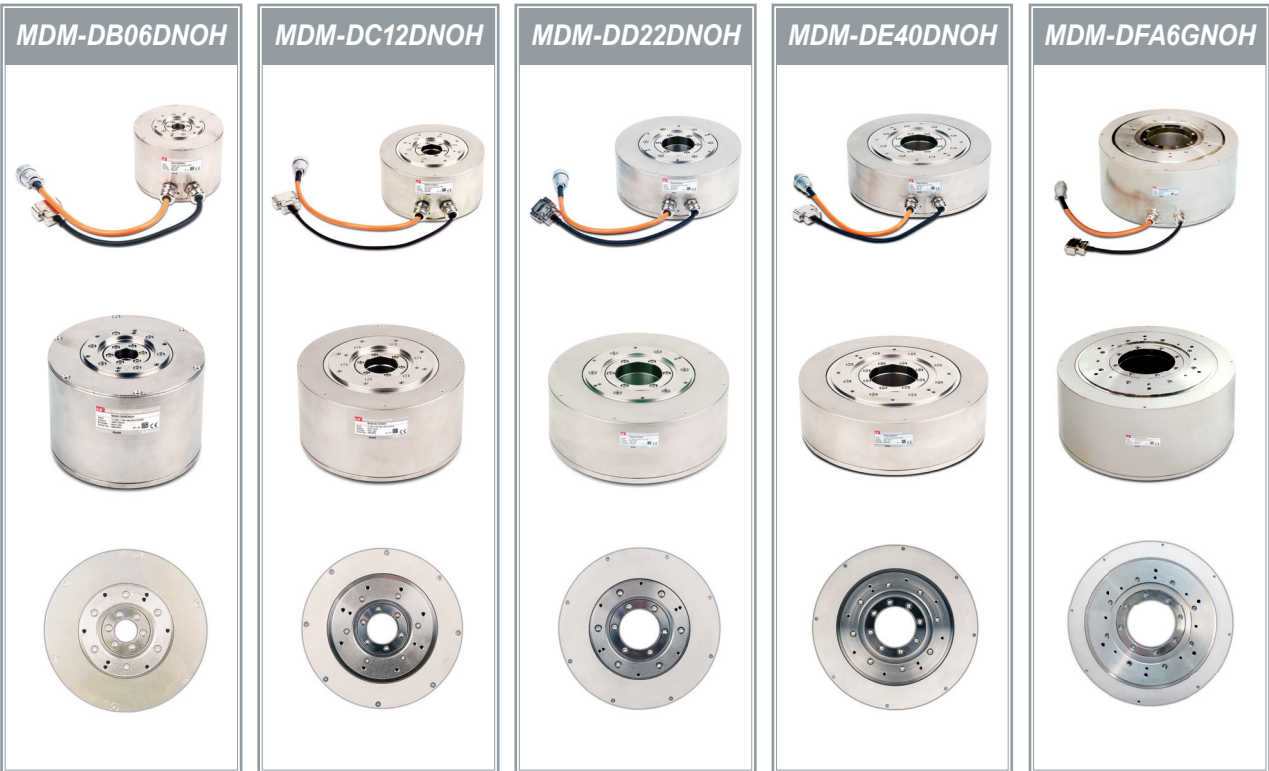

INDUSTRIAL DD MOTOR SYSTEM

Identifying the Parts of L7

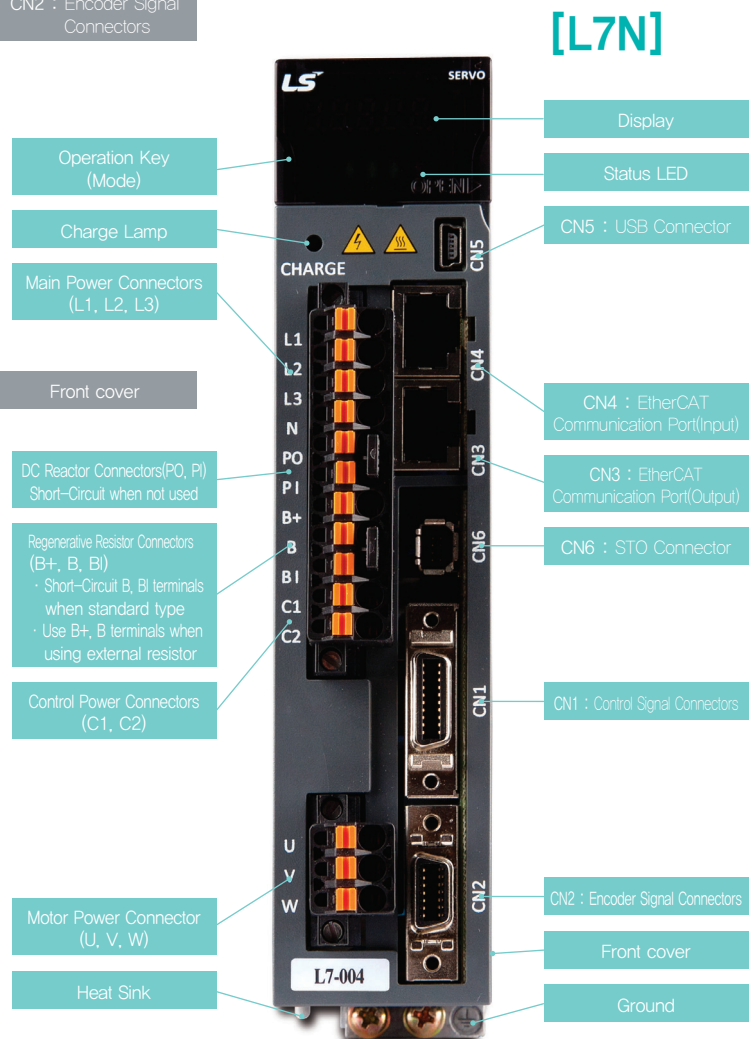
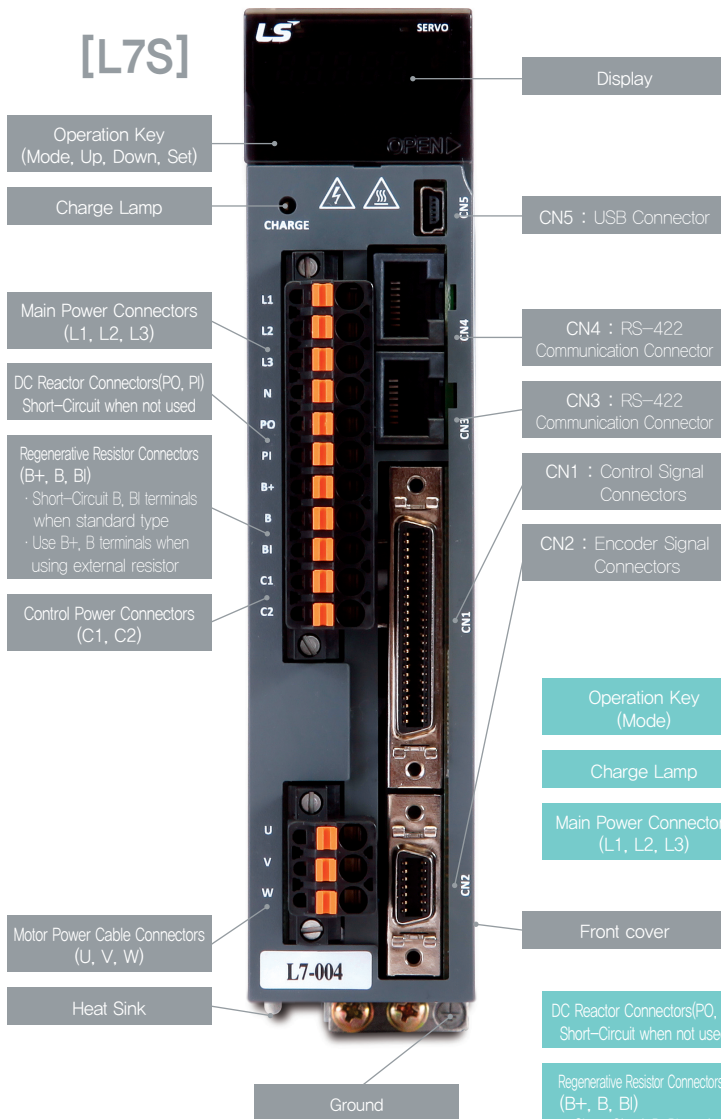

L7S Product Features

Item		Model	L7SA001□	L7SA002□	L7SA004□	L7SA008□	L7SA010□	L7SA020□	L7SA035□	
Input Power	Main Power Supply	3 Phase AC200 ~ 230[V](−15 ~ +10[%]), 50 ~ 60[Hz]								
	Control Power Supply	Single Phase AC200 ~ 230[V](−15 ~ +10[%]), 50 ~ 60[Hz]								
Rated Current[A]		1,4	1,7	3,0	5,2	6,75	13,5	16,7		
Peak Current[A]		4,2	5,1	9,0	15,6	20,25	40,5	50,1		
Encoder Type		Quad. Type Incremental Line Driver Max 10000[P/R] Serial Type 19Bit								
Performance	Speed Control	Speed Control Range	Max. 1 : 5000							
		Frequency Response	Max. 1[kHz] or above(When using 19bit Serial Encoder)							
		Speed Command	DC−10[V]~+10[V](Reverse rotation in case of − voltage)							
		Accel/Decel Time	Linear or S–Shape Accel/Decel.(0~10,000[ms], Setting 1[ms] is possible)							
		Speed Variation Ratio	±0,01[%] or less [at Load variation 0 ~ 100%] ±0,1[%] or less [at Temp. 25±10°C]							
	Position Control	Input Frequency	1[Mpps], Line Driver / 200[kpps], Open Collector							
		Input Pulse Type	+Pulse, CW+CCW, A/B Phase							
		Electric Gear Ratio	Setting and selecting 4 digital electric gear ratio, Precise adjustment is possible							
	Torque Control	Torque Command	DC −10 ~ +10[V](Reverse rotation in case of − voltage)							
		Speed Limit	DC 0 ~ +10[V], within ±1[%] of internal speed command							
Repeatability		±1[%] or less								
Input/Output Signal	Analog Input	Input Range	DC −10 ~ +10[V]							
		Resolution	12[bit]							
	Digital Input	Total 10 Input Channels(assignment available) SVON, SPD1, SPD2, SPD3, ALMRST, DIR, CCWLIM, CWLIM, EMG, STOP, EGEAR1, EGEAR2, PCON, GAIN2, P_CLR, T_LMT, MODE, ABS_RQ, ZCLAMP Above 19 functions can be used selectively for assignment Signal can be set as positive logic or negative logic								
		Digital Output	Total 5 Channels(assignment available), 3 Channels(set as alarm code) ALARM, READY, ZSPD, BRAKE, INPOS, TLMT, VLMT, INSPD, WARN Above 9 outputs can be used selectively for assignment Signal can be set as positive logic or negative logic							
Communication	RS422	PC Software and RS422 Server are available								
	USB	Status monitoring, JOG operation, parameter upload/download are available with PC Software								
Encoder		Compatible with Serial Biss encoder, Paralled encoder								
Encoder Output Type		Random pre–scale output by FPGA(Max. 6.4Mpps)								
Built–in Function	Dynamic Braking	Built–in type(operates when Servo alarm or Servo off)								
	Regenerative Braking	Built–in type, and also external connection is available								
	Display	7 segments(5DIGIT)								
	Setting Function	Loader([SET], [MODE], [UP], [DOWN] key)								
	Additional Function	Automatic gain tuning function, Z–phase detection, manual JOG operation, program JOG operation, analog–input auto Calibration function								
Protective Function		Overcurrent, overload, overvoltage, insufficient voltage, main power input problem, control power input problem, overspeed, motor cable, overheat(power module overheat, abnormal drive operation's temp), encoder problem, over–regenerative, sensor problem, communication problem								
Operation Environment	Temperature	0 ~ 50[°C]								
	Humidity	Below 90[%]RH(avoid dew–condensation)								
	Ambient Environment	Indoor, Avoid corrosive, inflammable gas or liquid, and electrically conductive dust.								

INDUSTRIAL DD MOTOR SYSTEM

L7N Product Features

Item		Name	L7NA001B	L7NA002B	L7NA004B	L7NA008B	L7NA010B	L7NA020B	L7NA035B
Input power	Main power	3-phase AC200 ~ 230[V](-15 ~ +10[%]), 50 ~ 60[Hz]							
	Control power	Single-phase AC200 ~ 230[V](-15 ~ +10[%]), 50 ~ 60[Hz]							
Rated current[A]		1.4	1.7	3.0	5.2	6.75	13.5	16.7	
Peak current[A]		4.2	5.1	9.0	15.6	20.25	40.5	50.1	
Encoder Type		Serial 17bit / 19bit / 21bit							
Control performance	Speed Control Range	Maximum 1 : 5000							
	Frequency response	Maximum 1kHz or more(when the 19-bit serial encoder is applied)							
	Speed change rate	±0.01[%] or lower(when the load changes between 0 and 100%) ±0.1[%] or less(temperature of 25°C[±10])							
	Torque control repetition accuracy	Within ±1%							
Supported drive modes (CiA402)		Profile Position Mode Profile Velocity Mode Profile Torque Mode Interpolated Position Mode Cyclic Synchronous Position Mode Cyclic Synchronous Velocity Mode Cyclic Synchronous Torque Mode Homing Mode							
Digital input / output	Digital input	Total 6 input channels(allocable) PCON, GAIN2, ALMRST, HOME, P-OT, N-OT Above 6 functions can be used selectively for assignment. Signal can be set as positive logic or negative logic							
	Touch Probe input	There are 2 input channels. Provides rising and falling edge detection functions for each channel.							
	Digital output	Total 4 channels(allocable) ALARM, READY, ZSPD, BRAKE, INPOS, INSPD, WARN Above 7 outputs can be used selectively for assignment. Signal can be set as positive logic or negative logic.							
Additional communication	USB	Program download is available with USB Communication.							
Built-in functions	Dynamic braking	Built-in type(operates when Servo alarm or Servo off)							
	Regenerative braking	Built-in type, and also external connection is available							
	Display function	7 segments(5 DIGIT)							
	Self-setting function	The [MODE] key changes the content displayed in the 7 segments.							
	Additional function	Auto gain tuning function							
	Protection function	Overcurrent, overload, overvoltage, insufficient voltage, main power input problem, control power input problem, overspeed, motor cable, overheat(power module overheat, abnormal drive operation's temp), encoder problem, over-regenerative, sensor problem, communication problem							
Operation Environment	Temperature	0 ~ 50[°C]							
	Humidity	Below 90[%]RH(avoid dew-condensation)							
	Ambient Environment	Indoor, Avoid corrosive, inflammable gas or liquid, and electrically conductive dust.							

External Dimensions of Servo Drive

■ L7□A001□ ~ L7□A004□ [Weight : 1.2kg]

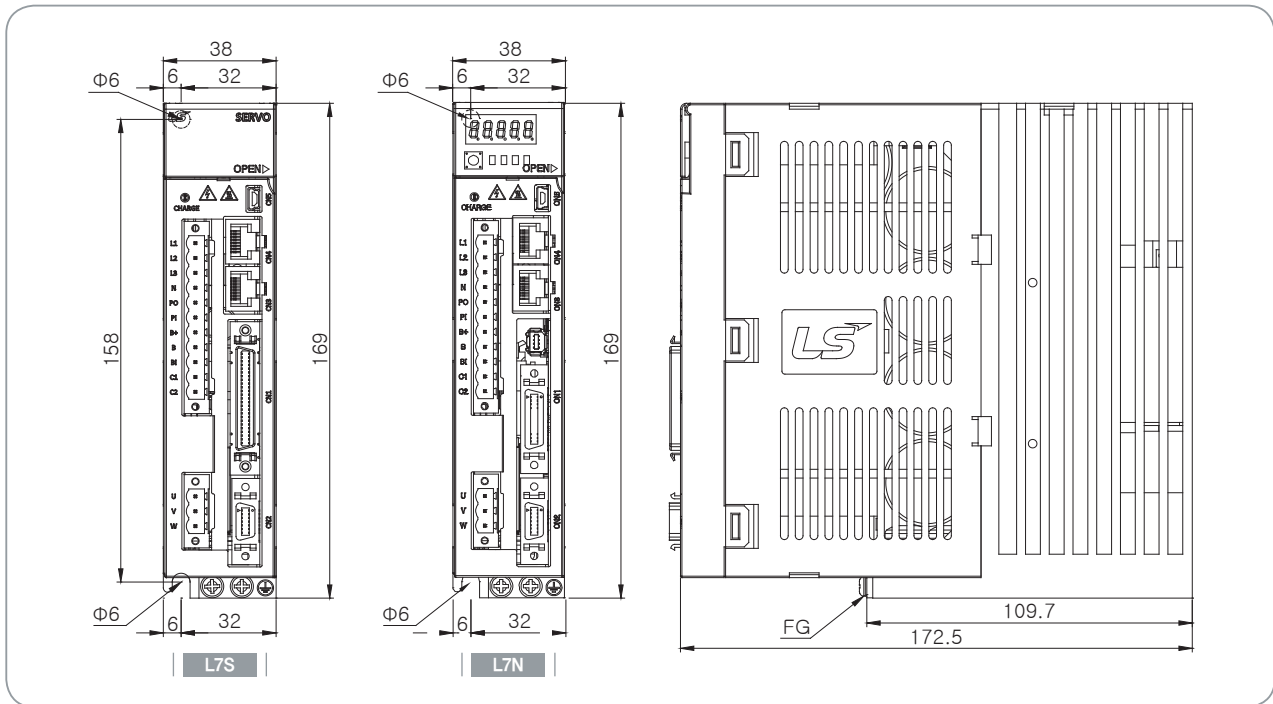

■ L7□A008□ ~ L7□A010□ [Weight : 1.5kg(Fan-Cooling included)]

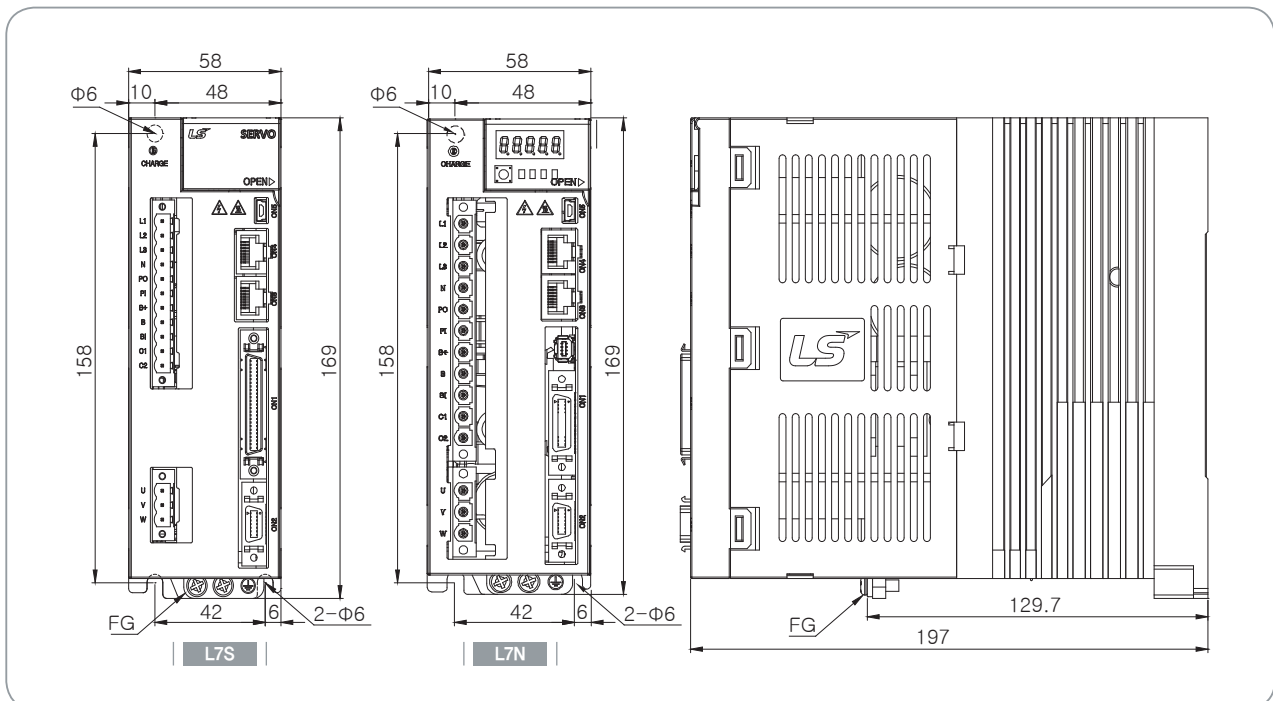

INDUSTRIAL DD MOTOR SYSTEM

External Dimensions of Servo Drive

■ L7□A020□ ~ L7□A035□ [Weight : 2.5kg(Fan-Cooling included)]

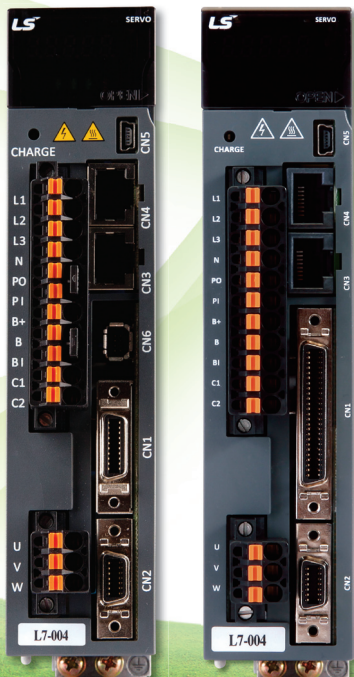
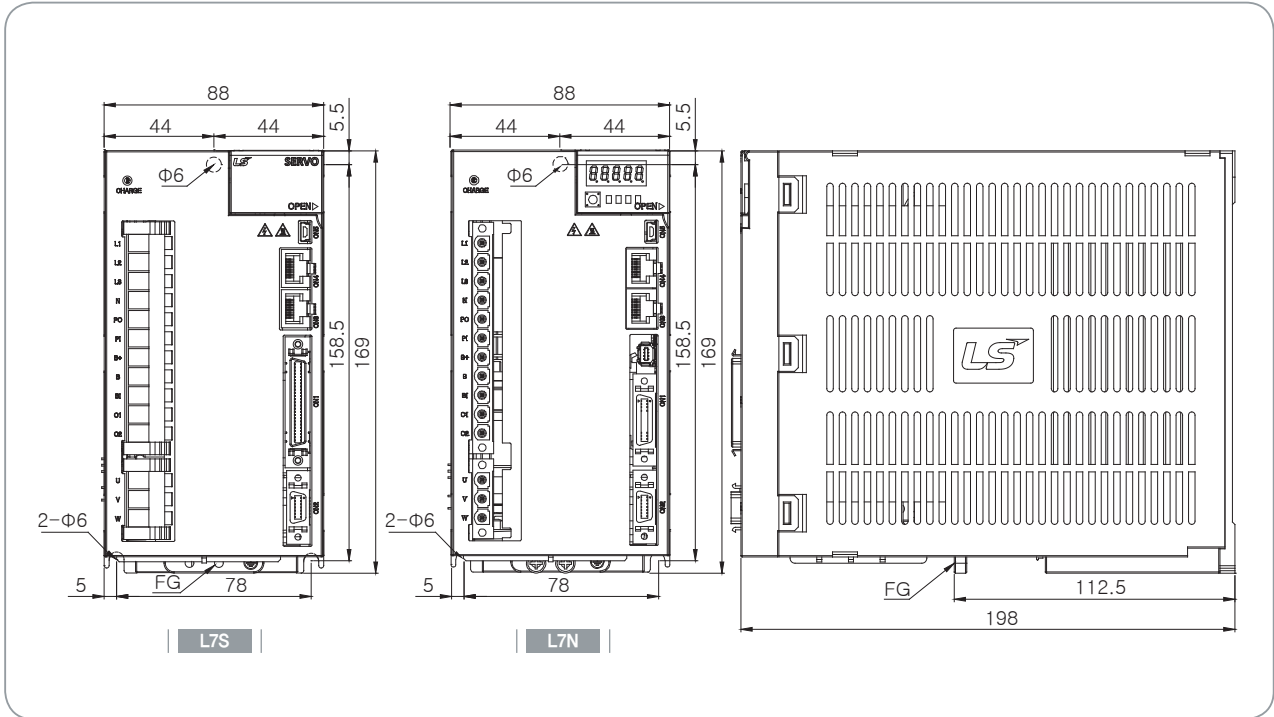

LS Mecapion

L7 Series - Servo Drive

External Dimensions of Direct-Drive Rotary Motor

MDM-DB03D, MDM-DB06D, MDM-DB09D

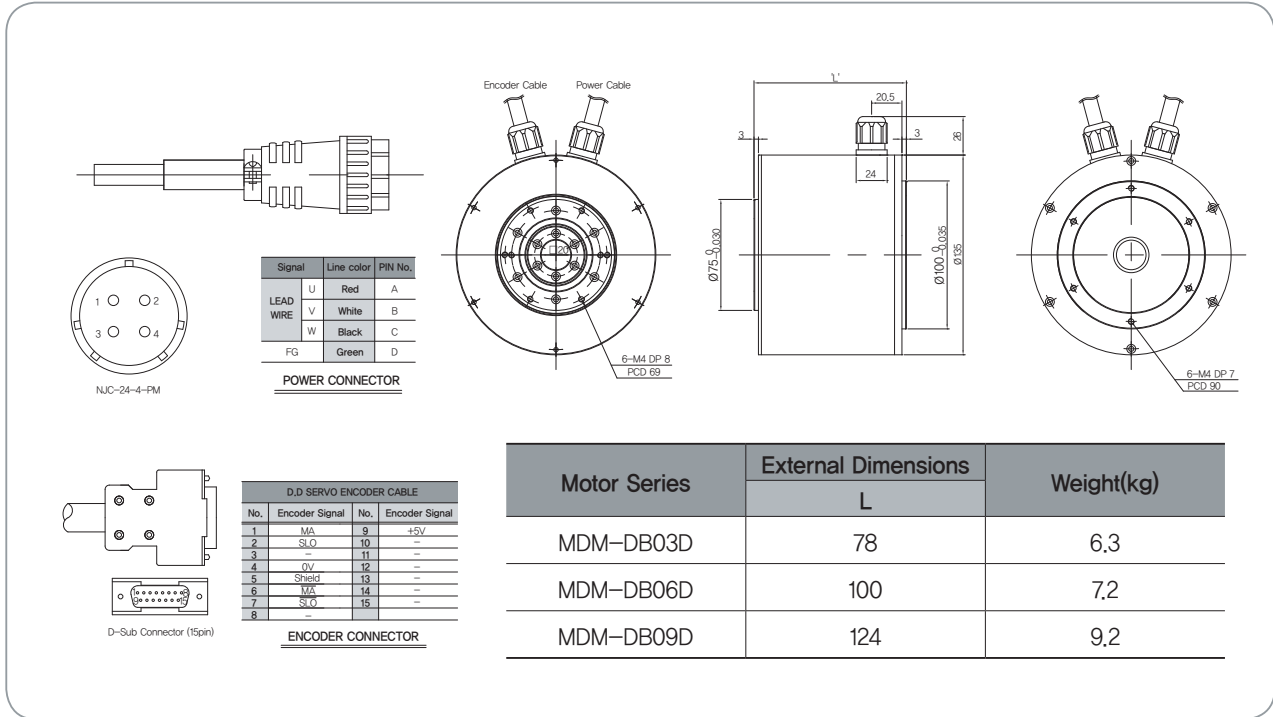

MDM-DC06D, MDM-DC12D, MDM-DC18D

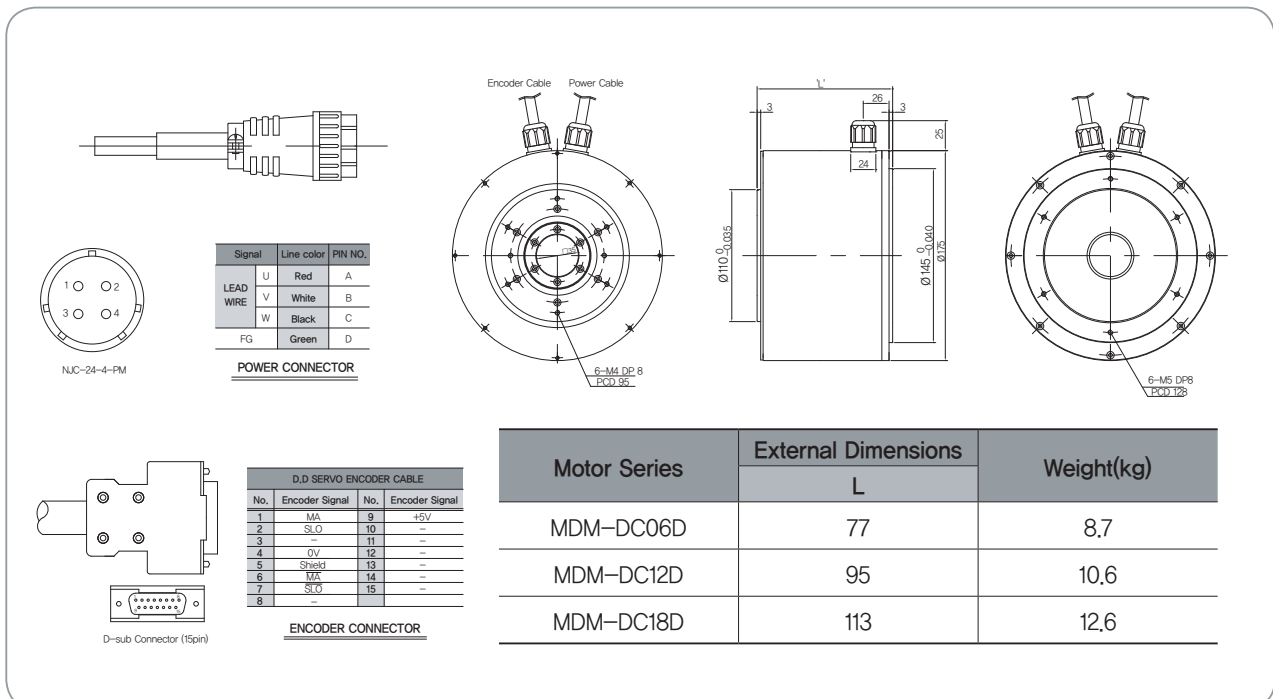

INDUSTRIAL DD MOTOR SYSTEM

External Dimensions of Direct-Drive Rotary Motor

MDM-DD12D, MDM-DD22D, MDM-DD34D

NJC-24-4-PM

Signal	Line color	PIN NO.
U	Red	A
V	White	B
W	Black	C
FG	Green	D

POWER CONNECTOR

D-Sub Connector (15pin)

D.D SERVO ENCODER CABLE			
No.	Encoder Signal	No.	Encoder Signal
1	MA	9	+5V
2	SLO	10	-
3	-	11	-
4	0V	12	-
5	Shield	13	-
6	MA	14	-
7	SLO	15	-
8	-	-	-

ENCODER CONNECTOR

Motor Series	External Dimensions	Weight(kg)
	L	
MDM-DD12D	82.5	17.3
MDM-DD22D	100.5	19.6
MDM-DD34D	118.5	21.9

MDM-DE40D, MDM-DE60D

NJC-24-4-PM

Signal	Line color	PIN NO.
U	Red	A
V	White	B
W	Black	C
FG	Green	D

POWER CONNECTOR

D-sub Connector (15pin)

D.D SERVO ENCODER CABLE			
No.	Encoder Signal	No.	Encoder Signal
1	MA	9	+5V
2	SLO	10	-
3	-	11	-
4	0V	12	-
5	Shield	13	-
6	MA	14	-
7	SLO	15	-
8	-	-	-

ENCODER CONNECTOR

Motor Series	External Dimensions	Weight(kg)
	L	
MDM-DE40D	95.4	28.2
MDM-DE60D	113.4	35

External Dimensions of Direct-Drive Rotary Motor

MDM-DFA1G, MDM-DFA6G

Technical drawings showing the external dimensions and connector details for the MDM-DFA1G and MDM-DFA6G motors. The drawings include a side view with dimensions (276-0.052, 2.5, 28, 28, 60°±2'30", 6-M8 DP 7 PCD 300) and a top view with dimensions (276-0.052, 2.5, 28, 28, 60°±2'30", 6-M8 DP 7 PCD 300). The top view also shows the encoder cable and power cable connections.

POWER CONNECTOR

Signal	Line color	PIN NO.
U	Red	A
V	White	B
W	Black	C
FG	Green	D

Nanaboshi Electronic
NUC-24-4-PM

6-M8 Tap DP16
PCD 232

6-M8 DP 7
PCD 300

D.D SERVO ENCODER CABLE

No.	Encoder Signal	No.	Encoder Signal
1	MA	9	+5V
2	SLO	10	-
3	-	11	-
4	OV	12	-
5	Shield	13	-
6	MA	14	-
7	SLO	15	-
8	-	-	-

D-sub Connector (15pin)

Motor Series	External Dimensions	Weight(kg)
	L	
MDM-DFA1G	131	43.6
MDM-DFA6G	167	48.5

LS Mecapion
DD Motor Series



INDUSTRIAL DD MOTOR SYSTEM

Features of Direct Drive Motor

Motor Designation		MDM-DB□□D□H			MDM-DC□□D□H		
		03	06	09	06	12	18
Applicable Drive (L7□-A□□□□)		001B	002B	004B	002B	004B	004B
Flange Size	mm	Φ135			Φ175		
Rated Output	W	63	126	188	126	251	377
Rated Torque	N-m	3	6	9	6	12	18
Max Torque	N-m	9	18	27	18	36	54
Rated Current	Arms	1.12	1.46	2.63	1.48	2.41	3.0
Max Current	Arms	3.36	4.38	7.89	4.44	7.23	9.0
Rated Speed	rpm	200			200		
Max Speed	rpm	500	500	500	500	500	400
Constant of Torque	N-m/Arms	2.76	4.25	3.57	4.18	5.13	6.12
Inertia	kg-m ² ×10 ⁻⁴	5.74	8.67	11.5	27.32	38.9	50.48
Rated Power Rate	kW/s	15.68	42.35	70.43	13.18	52.71	118.59
Angular acceleration	rad/s ²	191.2	141.6	127.7	455.03	323.9	280.3
positioning accuracy	arc-sec	±30					
positioning repeatability	arc-sec	±2					
Axial run-out	mm	0,05					
Radial run-out	mm	0,05					
Allowable Thrust Load	N	1500			3300		
Max. Instantaneous	N-m	40			70		
Encoder Type		20-bit single turn serial encoder(Biss/Absolute)					
Weight (Approx.)	kg	6.3	7.2	9.2	8.7	10.6	12.6
Working Environment	Ambient Temp	operating : 0~40[°C] / storage : -20~60[°C]					
	Ambient Humidity	20~80[%] RH(avoid dew-condensation)					
	Atmosphere	Avoid direct sunlight, No corrosive gas, Inflammable gas, Oil mist, or Dust					

Speed-Torque Characteristics

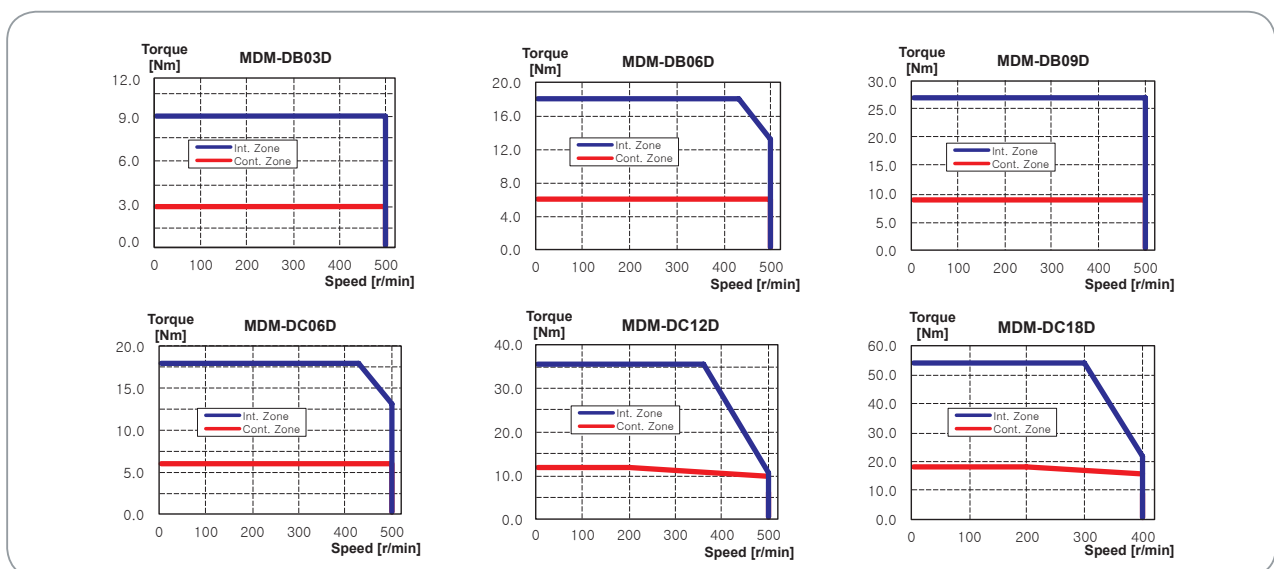

Features of Direct Drive Motor

Motor Designation		MDM-DD□□D□H			MDM-DE□□D□H		MDM-DF□□G□H	
		12	22	34	40	60	A1	A6
Applicable Drive (L7□-A□□□□)		004B	008B	010B	010B	020B	020B	035B
Flange Size	mm	Φ230			Φ290		Φ360	
Rated Output	W	251	461	712	838	1,257	1,728	2,513
Rated Torque	N-m	12	22	34	40	60	110	160
Max Torque	N-m	36	66	102	120	180	330	480
Rated Current	Arms	2.58	3.33	5.72	5.3	8.33	9.48	14.6
Max Current	Arms	7.74	9.99	17.16	15.9	24.99	28.44	43.8
Rated Speed	rpm	200			200		150	
Max Speed	rpm	500	400	400	300	300	250	250
Constant of Torque	N-m/Arms	4.8	6.81	6.13	7.77	7.42	10.24	9.53
Inertia	kg-m ² ×10 ⁻⁴	54.14	68.15	82.16	311.55	371.71	1410.2	1763.4
Rated Power Rate	kW/s	26.6	71.02	140.7	51.36	96.68	85.9	145.4
Angular acceleration	rad/s ²	450.9	309.6	241.5	778.35	619.1	1281.13	1101.4
positioning accuracy	arc-sec	±30						
positioning repeatability	arc-sec	±2						
Axial run-out	mm	0.05						
Radial run-out	mm	0.05						
Allowable Thrust Load	N	4000			11000		15000	
Max. Instantaneous	N-m	93			250		350	
Encoder Type		20-bit single turn serial encoder(Biss/Absolute)						
Weight (Approx.)	kg	17.3	19.6	21.9	28.2	35	43.6	48.5
Working Environment	Ambient Temp	operating : 0~40[°C] / storage : -20~60[°C]						
	Ambient Humidity	20~80[%] RH(avoid dew-condensation)						
	Atmosphere	Avoid direct sunlight, No corrosive gas, Inflammable gas, Oil mist, or Dust						

Speed-Torque Characteristics

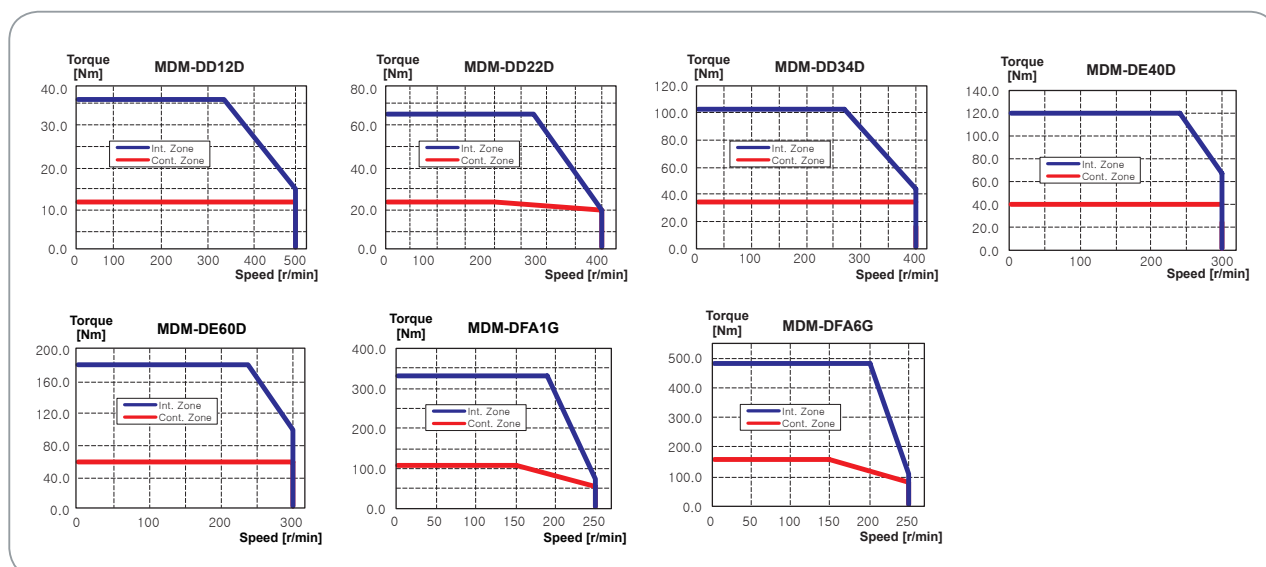

INDUSTRIAL DD MOTOR SYSTEM

Specifications for Options

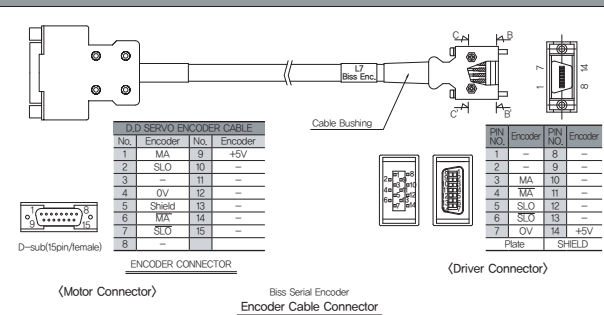
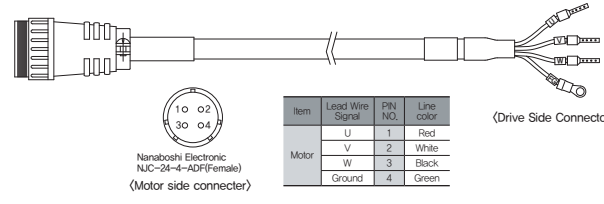
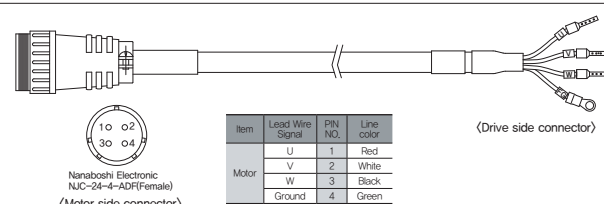
Type	Product type	Model Name(Notes1)	Applicable Motor	Specifications																																																																								
For Signal	L7 Encoder Cable	APCS-E□□□ZS	All models of DD motor	 <p>D.D. SERVO ENCODER CABLE</p> <table border="1"> <thead> <tr> <th>No.</th> <th>Encoder</th> <th>No.</th> <th>Encoder</th> </tr> </thead> <tbody> <tr><td>1</td><td>MA</td><td>9</td><td>+5V</td></tr> <tr><td>2</td><td>SLO</td><td>10</td><td>--</td></tr> <tr><td>3</td><td>--</td><td>11</td><td>--</td></tr> <tr><td>4</td><td>OV</td><td>12</td><td>--</td></tr> <tr><td>5</td><td>Shield</td><td>13</td><td>--</td></tr> <tr><td>6</td><td>MA</td><td>14</td><td>--</td></tr> <tr><td>7</td><td>SLO</td><td>15</td><td>--</td></tr> <tr><td>8</td><td>--</td><td>--</td><td>--</td></tr> </tbody> </table> <p>ENCODER CONNECTOR</p> <table border="1"> <thead> <tr> <th>Pin No.</th> <th>Encoder</th> <th>Pin No.</th> <th>Encoder</th> </tr> </thead> <tbody> <tr><td>1</td><td>--</td><td>8</td><td>--</td></tr> <tr><td>2</td><td>--</td><td>9</td><td>--</td></tr> <tr><td>3</td><td>MA</td><td>10</td><td>--</td></tr> <tr><td>4</td><td>MA</td><td>11</td><td>--</td></tr> <tr><td>5</td><td>SLO</td><td>12</td><td>--</td></tr> <tr><td>6</td><td>SLO</td><td>13</td><td>--</td></tr> <tr><td>7</td><td>OV</td><td>14</td><td>+5V</td></tr> <tr><td>Plate</td><td>SHIELD</td><td>--</td><td>--</td></tr> </tbody> </table> <p>1. Motor Side Connector a. Connector(D-SUB) : DA-15PF-N(Made by Female) b. Connector CASE(D-SUB) : SK-15H-1A</p> <p>2. Drive Side Connector a. CASE Spec. : 10314-52A0-008(Made by 3M) b. Connector Spec. : 10114-3000VE(Made by 3M)</p> <p>3. Cable Spec. : 3P×0,2SQ</p>	No.	Encoder	No.	Encoder	1	MA	9	+5V	2	SLO	10	--	3	--	11	--	4	OV	12	--	5	Shield	13	--	6	MA	14	--	7	SLO	15	--	8	--	--	--	Pin No.	Encoder	Pin No.	Encoder	1	--	8	--	2	--	9	--	3	MA	10	--	4	MA	11	--	5	SLO	12	--	6	SLO	13	--	7	OV	14	+5V	Plate	SHIELD	--	--
No.	Encoder	No.	Encoder																																																																									
1	MA	9	+5V																																																																									
2	SLO	10	--																																																																									
3	--	11	--																																																																									
4	OV	12	--																																																																									
5	Shield	13	--																																																																									
6	MA	14	--																																																																									
7	SLO	15	--																																																																									
8	--	--	--																																																																									
Pin No.	Encoder	Pin No.	Encoder																																																																									
1	--	8	--																																																																									
2	--	9	--																																																																									
3	MA	10	--																																																																									
4	MA	11	--																																																																									
5	SLO	12	--																																																																									
6	SLO	13	--																																																																									
7	OV	14	+5V																																																																									
Plate	SHIELD	--	--																																																																									
For Power	L7 Power Cable	APCS-PN□□YS	DB03D/06D/09D DC06D/12D/18D DD12D/22D/34D DE40D/60D	 <p>Motor side connector</p> <table border="1"> <thead> <tr> <th>Item</th> <th>Lead Wire Signal</th> <th>Pin NO.</th> <th>Line color</th> </tr> </thead> <tbody> <tr><td>Motor</td><td>U</td><td>1</td><td>Red</td></tr> <tr><td></td><td>V</td><td>2</td><td>White</td></tr> <tr><td></td><td>W</td><td>3</td><td>Black</td></tr> <tr><td></td><td>Ground</td><td>4</td><td>Green</td></tr> </tbody> </table> <p>1. Motor Side Connector a. PLUG Spec. : NJC-24-4-ADF(Made by Female)</p> <p>2. Drive Side Connector a. u,v,w Spec. : UA-F2012 b. FG Spec. : 1,5×4</p> <p>3. Cable Spec. : 4C×1,5SQ, LAPP Cable(P/N : 00257001)</p>	Item	Lead Wire Signal	Pin NO.	Line color	Motor	U	1	Red		V	2	White		W	3	Black		Ground	4	Green																																																				
Item	Lead Wire Signal	Pin NO.	Line color																																																																									
Motor	U	1	Red																																																																									
	V	2	White																																																																									
	W	3	Black																																																																									
	Ground	4	Green																																																																									
For Power	L7 Power Cable	APCS-PN□□ZS	DFA1G DFA6G	 <p>Motor side connector</p> <table border="1"> <thead> <tr> <th>Item</th> <th>Lead Wire Signal</th> <th>Pin NO.</th> <th>Line color</th> </tr> </thead> <tbody> <tr><td>Motor</td><td>U</td><td>1</td><td>Red</td></tr> <tr><td></td><td>V</td><td>2</td><td>White</td></tr> <tr><td></td><td>W</td><td>3</td><td>Black</td></tr> <tr><td></td><td>Ground</td><td>4</td><td>Green</td></tr> </tbody> </table> <p>1. Motor Side Connector a. PLUG Spec. : NJC-24-4-ADF(Made by Female)</p> <p>2. Drive Side Connector a. u,v,w Spec. : UA-F2012 b. FG Spec. : 2,5×4</p> <p>3. Cable Spec. : 4C×2,5SQ, LAPP Cable(P/N : 00257011)</p>	Item	Lead Wire Signal	Pin NO.	Line color	Motor	U	1	Red		V	2	White		W	3	Black		Ground	4	Green																																																				
Item	Lead Wire Signal	Pin NO.	Line color																																																																									
Motor	U	1	Red																																																																									
	V	2	White																																																																									
	W	3	Black																																																																									
	Ground	4	Green																																																																									

Specifications for Options[Signal Cable]

Type	Product type	Model Name(Note1)	Applicable Motor	Specifications																																																																																																													
For Signal	CN1 Cable	APC-CN1□□A	L7S SERIES	<p>[Upper Controller] [Drive Connection Side CN1]</p> <p>Indicates Pin No</p> <p>1. Drive Side Connection(CN1) a. Case Spec. : 10350-52A0-008(Made by 3M) b. Connector Spec. : 10150-3000VE(Made by 3M) c. Cable Spec. : 20276-SB 25P(AWG28)</p>																																																																																																													
	<p>(Pin No. Display)</p> <table border="1"> <thead> <tr> <th>CN1</th> <th>I/O Signal</th> <th>CN1</th> <th>I/O Signal</th> <th>CN1</th> <th>I/O Signal</th> <th>CN1</th> <th>I/O Signal</th> <th>CN1</th> <th>I/O Signal</th> </tr> </thead> <tbody> <tr> <td>1</td> <td>TRGCOM</td> <td>11</td> <td>PR+</td> <td>21</td> <td>SPD3</td> <td>31</td> <td>/BO</td> <td>41</td> <td>RDY-</td> </tr> <tr> <td>2</td> <td>REFCOM</td> <td>12</td> <td>PR-</td> <td>22</td> <td>SPD2</td> <td>32</td> <td>AO</td> <td>42</td> <td>TLOUT</td> </tr> <tr> <td>3</td> <td>PZO</td> <td>13</td> <td>PCON</td> <td>23</td> <td>SPD1</td> <td>33</td> <td>/AO</td> <td>43</td> <td>ZSPD</td> </tr> <tr> <td>4</td> <td>ZO</td> <td>14</td> <td>GAIN2(SEN)</td> <td>24</td> <td>GND</td> <td>34</td> <td>+5V</td> <td>44</td> <td>BRAKE</td> </tr> <tr> <td>5</td> <td>/ZO</td> <td>15</td> <td>PCLEAR</td> <td>25</td> <td>GND</td> <td>35</td> <td>-15V</td> <td>45</td> <td>INSPD/INPOS</td> </tr> <tr> <td>6</td> <td>SRO</td> <td>16</td> <td>TLIMIT</td> <td>26</td> <td>SETCOM</td> <td>36</td> <td>GND</td> <td>46</td> <td>DIR</td> </tr> <tr> <td>7</td> <td>/SRO</td> <td>17</td> <td>ALMRST</td> <td>27</td> <td>SPDCOM</td> <td>37</td> <td>GND</td> <td>47</td> <td>SVON</td> </tr> <tr> <td>8</td> <td>GND</td> <td>18</td> <td>EMG</td> <td>28</td> <td>MONIT1</td> <td>38</td> <td>ALARM+</td> <td>48</td> <td>STOP</td> </tr> <tr> <td>9</td> <td>RF+</td> <td>19</td> <td>CWLIM</td> <td>29</td> <td>MONIT2</td> <td>39</td> <td>ALARM-</td> <td>49</td> <td>PULCOM</td> </tr> <tr> <td>10</td> <td>PF-</td> <td>20</td> <td>CCWLM</td> <td>30</td> <td>BO</td> <td>40</td> <td>RDY+</td> <td>50</td> <td>+24Vin</td> </tr> </tbody> </table>				CN1	I/O Signal	CN1	I/O Signal	CN1	I/O Signal	CN1	I/O Signal	CN1	I/O Signal	1	TRGCOM	11	PR+	21	SPD3	31	/BO	41	RDY-	2	REFCOM	12	PR-	22	SPD2	32	AO	42	TLOUT	3	PZO	13	PCON	23	SPD1	33	/AO	43	ZSPD	4	ZO	14	GAIN2(SEN)	24	GND	34	+5V	44	BRAKE	5	/ZO	15	PCLEAR	25	GND	35	-15V	45	INSPD/INPOS	6	SRO	16	TLIMIT	26	SETCOM	36	GND	46	DIR	7	/SRO	17	ALMRST	27	SPDCOM	37	GND	47	SVON	8	GND	18	EMG	28	MONIT1	38	ALARM+	48	STOP	9	RF+	19	CWLIM	29	MONIT2	39	ALARM-	49	PULCOM	10	PF-	20	CCWLM	30	BO	40	RDY+	50
CN1	I/O Signal	CN1	I/O Signal	CN1	I/O Signal	CN1	I/O Signal	CN1	I/O Signal																																																																																																								
1	TRGCOM	11	PR+	21	SPD3	31	/BO	41	RDY-																																																																																																								
2	REFCOM	12	PR-	22	SPD2	32	AO	42	TLOUT																																																																																																								
3	PZO	13	PCON	23	SPD1	33	/AO	43	ZSPD																																																																																																								
4	ZO	14	GAIN2(SEN)	24	GND	34	+5V	44	BRAKE																																																																																																								
5	/ZO	15	PCLEAR	25	GND	35	-15V	45	INSPD/INPOS																																																																																																								
6	SRO	16	TLIMIT	26	SETCOM	36	GND	46	DIR																																																																																																								
7	/SRO	17	ALMRST	27	SPDCOM	37	GND	47	SVON																																																																																																								
8	GND	18	EMG	28	MONIT1	38	ALARM+	48	STOP																																																																																																								
9	RF+	19	CWLIM	29	MONIT2	39	ALARM-	49	PULCOM																																																																																																								
10	PF-	20	CCWLM	30	BO	40	RDY+	50	+24Vin																																																																																																								
For Signal	CN1 Cable	APCS-CN1□□A	L7N SERIES	<p>[Upper Controller] [Drive Connection Side CN1]</p> <p>Indicates Pin No</p> <p>1. Drive Side Connection(CN1) a. Case Spec. : 10320-52A0-008(Made by 3M) b. Connector Spec. : 10120-3000VE(Made by 3M)</p>																																																																																																													
	<p>(Pin No. Display)</p> <table border="1"> <thead> <tr> <th>NO</th> <th>Signal</th> <th>NO</th> <th>Signal</th> <th>NO</th> <th>Signal</th> <th>NO</th> <th>Signal</th> </tr> </thead> <tbody> <tr> <td>1</td> <td>BRAKE+</td> <td>6</td> <td>24V</td> <td>11</td> <td>HOME</td> <td>16</td> <td>Spare Pin</td> </tr> <tr> <td>2</td> <td>BRAKE-</td> <td>7</td> <td>CWL</td> <td>12</td> <td>ALMRST</td> <td>17</td> <td>RDY+</td> </tr> <tr> <td>3</td> <td>ALARM+</td> <td>8</td> <td>CCWL</td> <td>13</td> <td>DI1</td> <td>18</td> <td>RDY-</td> </tr> <tr> <td>4</td> <td>ALARM-</td> <td>9</td> <td>PROBE1</td> <td>14</td> <td>DI2</td> <td>19</td> <td>DO1+</td> </tr> <tr> <td>5</td> <td>Spare Pin</td> <td>10</td> <td>PROBE2</td> <td>15</td> <td>Spare Pin</td> <td>20</td> <td>DO1-</td> </tr> </tbody> </table>				NO	Signal	NO	Signal	NO	Signal	NO	Signal	1	BRAKE+	6	24V	11	HOME	16	Spare Pin	2	BRAKE-	7	CWL	12	ALMRST	17	RDY+	3	ALARM+	8	CCWL	13	DI1	18	RDY-	4	ALARM-	9	PROBE1	14	DI2	19	DO1+	5	Spare Pin	10	PROBE2	15	Spare Pin	20	DO1-																																																													
NO	Signal	NO	Signal	NO	Signal	NO	Signal																																																																																																										
1	BRAKE+	6	24V	11	HOME	16	Spare Pin																																																																																																										
2	BRAKE-	7	CWL	12	ALMRST	17	RDY+																																																																																																										
3	ALARM+	8	CCWL	13	DI1	18	RDY-																																																																																																										
4	ALARM-	9	PROBE1	14	DI2	19	DO1+																																																																																																										
5	Spare Pin	10	PROBE2	15	Spare Pin	20	DO1-																																																																																																										
For Signal	Communication Cable	APCS-CN5L7U	All Models of L7 SERIES	<p>[PC - USB Port] [Servo Drive - CN5]</p> <p>1. PC Side Connector : USB A Plug 2. Drive Side Connector(CN5) : Mini USB 5P Plug 3. Electric Requirements Spec : Double Shielded, Twisted Pair, EMI-filter attached type (Ex. : KU-AMB518, Made by SANWA)</p>																																																																																																													

Note1) □□ of Model Name indicates the Kind and length of cable And the declaration is as below.

Cable Length(m)	1	2	3	5
Declaration	01	02	03	05

INDUSTRIAL DD MOTOR SYSTEM

Specifications for Options[Connectors]

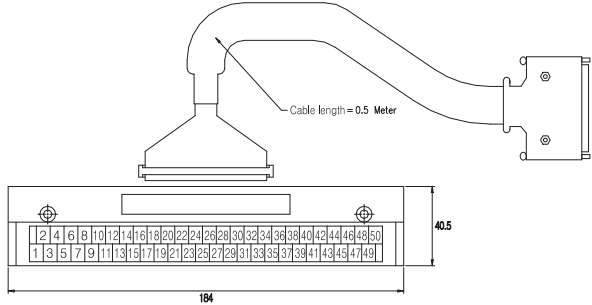
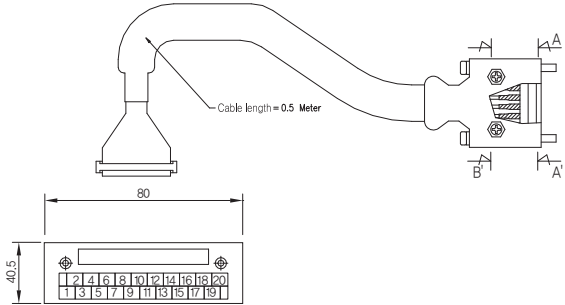
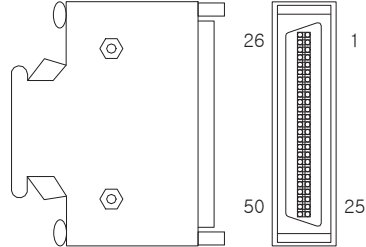
Type	Product type	Model Name(Note1)	Applicable Motor	Specifications																																																																																																													
T/B	CN1 T/B	APC-VSCN1T -□□	L7S SERIES	 <p>1. Extended CN1 T/B for VS/L7S 2. Available Cable Length : 0.5[m], 1[m], 1.5[m], 2[m], 3[m]</p>																																																																																																													
	<p>(Pin No. Display)</p> <table border="1"> <thead> <tr> <th>CN1</th> <th>I/O Signal</th> <th>CN1</th> <th>I/O Signal</th> <th>CN1</th> <th>I/O Signal</th> <th>CN1</th> <th>I/O Signal</th> <th>CN1</th> <th>I/O Signal</th> </tr> </thead> <tbody> <tr> <td>1</td> <td>TRGCOM</td> <td>11</td> <td>PR+</td> <td>21</td> <td>SPD3</td> <td>31</td> <td>/BO</td> <td>41</td> <td>RDY-</td> </tr> <tr> <td>2</td> <td>REFCOM</td> <td>12</td> <td>PR-</td> <td>22</td> <td>SPD2</td> <td>32</td> <td>/AO</td> <td>42</td> <td>TLOUT</td> </tr> <tr> <td>3</td> <td>PZO</td> <td>13</td> <td>PCON</td> <td>23</td> <td>SPD1</td> <td>33</td> <td>/AO</td> <td>43</td> <td>ZSPD</td> </tr> <tr> <td>4</td> <td>ZD</td> <td>14</td> <td>GAIN(SEN)</td> <td>24</td> <td>GND</td> <td>34</td> <td>+5V</td> <td>44</td> <td>BRAKE</td> </tr> <tr> <td>5</td> <td>/ZO</td> <td>15</td> <td>PCLER</td> <td>25</td> <td>GND</td> <td>35</td> <td>-5V</td> <td>45</td> <td>INSPD/INPOS</td> </tr> <tr> <td>6</td> <td>SRO</td> <td>16</td> <td>TLMIT</td> <td>26</td> <td>SETCOM</td> <td>36</td> <td>GND</td> <td>46</td> <td>DIR</td> </tr> <tr> <td>7</td> <td>/SRO</td> <td>17</td> <td>ALMRST</td> <td>27</td> <td>SPDCOM</td> <td>37</td> <td>GND</td> <td>47</td> <td>SVON</td> </tr> <tr> <td>8</td> <td>GND</td> <td>18</td> <td>EMG</td> <td>28</td> <td>MONIT1</td> <td>38</td> <td>ALARM+</td> <td>48</td> <td>STOP</td> </tr> <tr> <td>9</td> <td>RF+</td> <td>19</td> <td>CWLM</td> <td>29</td> <td>MONIT2</td> <td>39</td> <td>ALARM-</td> <td>49</td> <td>PULCOM</td> </tr> <tr> <td>10</td> <td>PF-</td> <td>20</td> <td>CCWLM</td> <td>30</td> <td>BO</td> <td>40</td> <td>RDY+</td> <td>50</td> <td>+24VIn</td> </tr> </tbody> </table>				CN1	I/O Signal	CN1	I/O Signal	CN1	I/O Signal	CN1	I/O Signal	CN1	I/O Signal	1	TRGCOM	11	PR+	21	SPD3	31	/BO	41	RDY-	2	REFCOM	12	PR-	22	SPD2	32	/AO	42	TLOUT	3	PZO	13	PCON	23	SPD1	33	/AO	43	ZSPD	4	ZD	14	GAIN(SEN)	24	GND	34	+5V	44	BRAKE	5	/ZO	15	PCLER	25	GND	35	-5V	45	INSPD/INPOS	6	SRO	16	TLMIT	26	SETCOM	36	GND	46	DIR	7	/SRO	17	ALMRST	27	SPDCOM	37	GND	47	SVON	8	GND	18	EMG	28	MONIT1	38	ALARM+	48	STOP	9	RF+	19	CWLM	29	MONIT2	39	ALARM-	49	PULCOM	10	PF-	20	CCWLM	30	BO	40	RDY+	50
CN1	I/O Signal	CN1	I/O Signal	CN1	I/O Signal	CN1	I/O Signal	CN1	I/O Signal																																																																																																								
1	TRGCOM	11	PR+	21	SPD3	31	/BO	41	RDY-																																																																																																								
2	REFCOM	12	PR-	22	SPD2	32	/AO	42	TLOUT																																																																																																								
3	PZO	13	PCON	23	SPD1	33	/AO	43	ZSPD																																																																																																								
4	ZD	14	GAIN(SEN)	24	GND	34	+5V	44	BRAKE																																																																																																								
5	/ZO	15	PCLER	25	GND	35	-5V	45	INSPD/INPOS																																																																																																								
6	SRO	16	TLMIT	26	SETCOM	36	GND	46	DIR																																																																																																								
7	/SRO	17	ALMRST	27	SPDCOM	37	GND	47	SVON																																																																																																								
8	GND	18	EMG	28	MONIT1	38	ALARM+	48	STOP																																																																																																								
9	RF+	19	CWLM	29	MONIT2	39	ALARM-	49	PULCOM																																																																																																								
10	PF-	20	CCWLM	30	BO	40	RDY+	50	+24VIn																																																																																																								
T/B	CN1 T/B	APC-L7NCN1T -□□	L7N SERIES	 <p>1. Extended CN1 T/B for L7N 2. Available Cable Length : 0.5[m], 1[m], 1.5[m], 2[m]</p>																																																																																																													
	<p>(Pin No. Display)</p> <table border="1"> <thead> <tr> <th>NO</th> <th>Signal</th> <th>NO</th> <th>Signal</th> <th>NO</th> <th>Signal</th> <th>NO</th> <th>Signal</th> </tr> </thead> <tbody> <tr> <td>1</td> <td>BRAKE+</td> <td>6</td> <td>24V</td> <td>11</td> <td>HOME</td> <td>16</td> <td>Spare Pin</td> </tr> <tr> <td>2</td> <td>BRAKE-</td> <td>7</td> <td>CWL</td> <td>12</td> <td>ALMRST</td> <td>17</td> <td>RDY+</td> </tr> <tr> <td>3</td> <td>ALARM+</td> <td>8</td> <td>CCWL</td> <td>13</td> <td>DI1</td> <td>18</td> <td>RDY-</td> </tr> <tr> <td>4</td> <td>ALARM-</td> <td>9</td> <td>PROBE1</td> <td>14</td> <td>DI2</td> <td>19</td> <td>DO1+</td> </tr> <tr> <td>5</td> <td>Spare Pin</td> <td>10</td> <td>PROBE2</td> <td>15</td> <td>Spare Pin</td> <td>20</td> <td>DO1-</td> </tr> </tbody> </table>				NO	Signal	NO	Signal	NO	Signal	NO	Signal	1	BRAKE+	6	24V	11	HOME	16	Spare Pin	2	BRAKE-	7	CWL	12	ALMRST	17	RDY+	3	ALARM+	8	CCWL	13	DI1	18	RDY-	4	ALARM-	9	PROBE1	14	DI2	19	DO1+	5	Spare Pin	10	PROBE2	15	Spare Pin	20	DO1-																																																													
NO	Signal	NO	Signal	NO	Signal	NO	Signal																																																																																																										
1	BRAKE+	6	24V	11	HOME	16	Spare Pin																																																																																																										
2	BRAKE-	7	CWL	12	ALMRST	17	RDY+																																																																																																										
3	ALARM+	8	CCWL	13	DI1	18	RDY-																																																																																																										
4	ALARM-	9	PROBE1	14	DI2	19	DO1+																																																																																																										
5	Spare Pin	10	PROBE2	15	Spare Pin	20	DO1-																																																																																																										
CN	CN1 Connector	APC-CN1NNA	L7S SERIES	 <p>1. Case Spec. : 10350-52A0-008(Made by 3M) 2. Connector Spec. : 10150-3000VE(Made by 3M)</p>																																																																																																													

Note1) □□ of Model Name indicates the kind and length of cable. And the declaration is as below.

*APC-VSCN1T

Cable Length(m)	0.5	1	1.5	2	3
Declaration	None	03	04	01	02

*APC-L7NCN1T

Cable Length(m)	0.5	1	1.5	2
Declaration	01	02	03	04

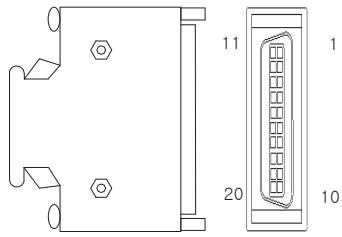
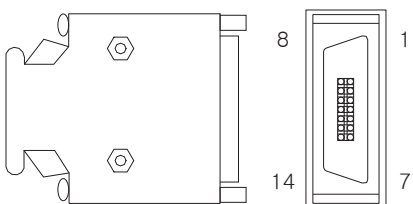
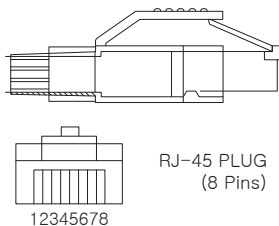
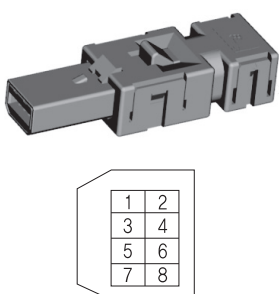
Type	Product type	Model Name ^(Note1)	Applicable Motor	Specifications																														
CN	CN1 Connector	APC-CN2NNA	L7N SERIES	 <p>1. Case Spec. : 10320-52A0-008(Made by 3M) 2. Connector Spec. : 10120-3000VE(Made by 3M)</p>																														
CN	CN2 Connector	APC-CN3NNA	All models of L7 Series	 <p>1. Case Spec. : 10314-52A0-008(Made by 3M) 2. Connector Spec. : 10114-3000VE(Made by 3M)</p>																														
CN	CN3 CN4 EtherCAT Connector	APCS-CN4NNA	L7N SERIES	 <table border="1" data-bbox="1157 1299 1412 1500"> <thead> <tr> <th>PIN No</th> <th>Signal</th> <th>Line color</th> </tr> </thead> <tbody> <tr> <td>1</td> <td>TX/RX0 Plus</td> <td>White/Orange</td> </tr> <tr> <td>2</td> <td>TX/RX0 Minus</td> <td>Orange</td> </tr> <tr> <td>3</td> <td>TX/RX1 Plus</td> <td>White/Orange</td> </tr> <tr> <td>4</td> <td>TX/RX2 Plus</td> <td>Blue</td> </tr> <tr> <td>5</td> <td>TX/RX2 Minus</td> <td>White/Blue</td> </tr> <tr> <td>6</td> <td>TX/RX1 Minus</td> <td>Rreen</td> </tr> <tr> <td>7</td> <td>TX/RX3 Plus</td> <td>White/Brown</td> </tr> <tr> <td>8</td> <td>TX/RX3 Minus</td> <td>Brown</td> </tr> <tr> <td></td> <td>Plate</td> <td>SHILDE</td> </tr> </tbody> </table> <p>Note) EtherCAT uses only 4 wires(1,2,3,6)</p>	PIN No	Signal	Line color	1	TX/RX0 Plus	White/Orange	2	TX/RX0 Minus	Orange	3	TX/RX1 Plus	White/Orange	4	TX/RX2 Plus	Blue	5	TX/RX2 Minus	White/Blue	6	TX/RX1 Minus	Rreen	7	TX/RX3 Plus	White/Brown	8	TX/RX3 Minus	Brown		Plate	SHILDE
PIN No	Signal	Line color																																
1	TX/RX0 Plus	White/Orange																																
2	TX/RX0 Minus	Orange																																
3	TX/RX1 Plus	White/Orange																																
4	TX/RX2 Plus	Blue																																
5	TX/RX2 Minus	White/Blue																																
6	TX/RX1 Minus	Rreen																																
7	TX/RX3 Plus	White/Brown																																
8	TX/RX3 Minus	Brown																																
	Plate	SHILDE																																
CN	CN6 Connector	APCS-CN6J	L7N SERIES	 <table border="1" data-bbox="1157 1713 1364 1982"> <thead> <tr> <th>PIN No</th> <th>I/O Signal</th> </tr> </thead> <tbody> <tr> <td>1</td> <td>NC</td> </tr> <tr> <td>2</td> <td>NC</td> </tr> <tr> <td>3</td> <td>HWBB1-</td> </tr> <tr> <td>4</td> <td>HWBB1+</td> </tr> <tr> <td>5</td> <td>HWBB2-</td> </tr> <tr> <td>6</td> <td>HWBB2+</td> </tr> <tr> <td>7</td> <td>EDM+</td> </tr> <tr> <td>8</td> <td>EDM-</td> </tr> </tbody> </table> <p>1. Spec. : 2040008-1(TE)</p>	PIN No	I/O Signal	1	NC	2	NC	3	HWBB1-	4	HWBB1+	5	HWBB2-	6	HWBB2+	7	EDM+	8	EDM-												
PIN No	I/O Signal																																	
1	NC																																	
2	NC																																	
3	HWBB1-																																	
4	HWBB1+																																	
5	HWBB2-																																	
6	HWBB2+																																	
7	EDM+																																	
8	EDM-																																	

INDUSTRIAL DD MOTOR SYSTEM

Specifications for Options [Braking Resistor]

□ Options

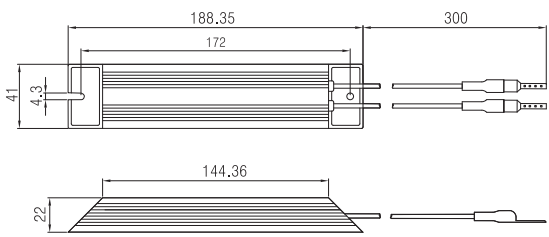
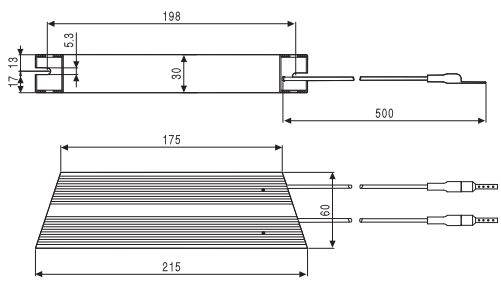
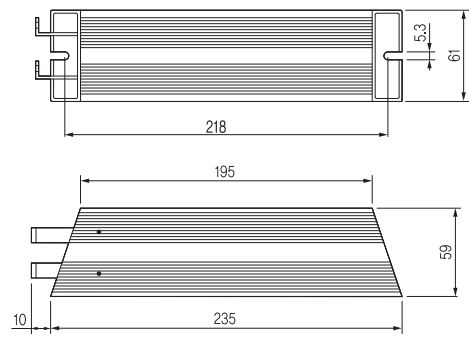
Type	Product type	Model Name(Notes)	Applicable Motor	Specifications
Resistor	Braking Resistor	APCS-140R50	L7□A001□ L7□A002□ L7□A004□	 <p>IRH 140W 50ohm</p>
Resistor	Braking Resistor	APCS-300R30	L7□A008□ L7□A010□	 <p>IRV 300W 30ohm</p>
Resistor	Braking Resistor	APC-600R30	L7□A020□ L7□A035□	 <p>IRV 600S 30ohm * L7□A020□ - Connects 2 pcs of resistance in parallel L7□A030□ - Connects 3 pcs of resistance in parallel</p> <p>IRV 600S 28ohm * L7□A050□ - 4pcs (Parallel Connection) Note) IRV 600S 30ohm and 600S 28ohm have the same external dimensions.</p>
		APC-600R28	L7□A050□ (4P)	

Note1) L7 Series 100W~7.5kW has the internal basic braking resistor.

If the machine requires short deceleration time frequently, refer to table above and apply the appropriate braking resistor.

MEMO





www.lsmecapion.com



Safety instructions

- For your safety, please read user's manual thoroughly before operating.
- Contact the nearest authorized service facility for examination, repair, or adjustment.
- Please contact qualified service technician when you need maintenance.
Do not disassemble or repair by yourself!
- Any maintenance and inspection shall be performed by the personnel having expertise concerned.

LS Mecapion Co., Ltd

Head Office Plant

(Hightech Industrial Park) 8-4, Hosandong-ro 12-9,
Dalseo-Gu, Daegu, Korea 704-240
T: +82-53-593-0066 F: +82-53-591-8614

Kyungin Center

104-605, SK-Ventium, Gosan-ro 166,
Gunpo, Gyeonggi-Do, Korea 435-776
T: +82-31-436-0600 F: +82-31-436-0604

China Factory

204-1, Xida Road, Meicun Industrial Center,
Xinqu, Wuxi, Jiangsu, China
T: +86-510-8295-3000 F: +86-510-8295-3019

Guangdong Office

Room 3, 12th floor, Huiye Building, No.17, Dongguan Avenue,
Dongcheng district, Dongguan City, Guangdong, China
T: +86-769-2332-9080/9081 F: +86-769-2332-9083